



QUEUE SOLUTIONS C series

C series is a modular Queue System. It directs the next customer to the first available room or counter. The call is made from a single button at each caller's location. The counter digit displays identify the caller's location. No tickets are required.

Display features:

- High contrast seven segment LEDs.
- 10 cm high for excellent visibility
- Integral power supply
- Integrated speaker
- Announcement bell
- Adjustable volume control
- Flush wall mounting
- pre-recorded voice announcement to say "Cashier number X please"
- Space for vinyl fixed lettering
- Painted case in any colour



Keypad functions:

- Single button push to announce callers' location



Over counter display:

- Identify which counter has called
- Flashes to attract attention
- Clearly visible 10cm high digits



Schematic Diagram

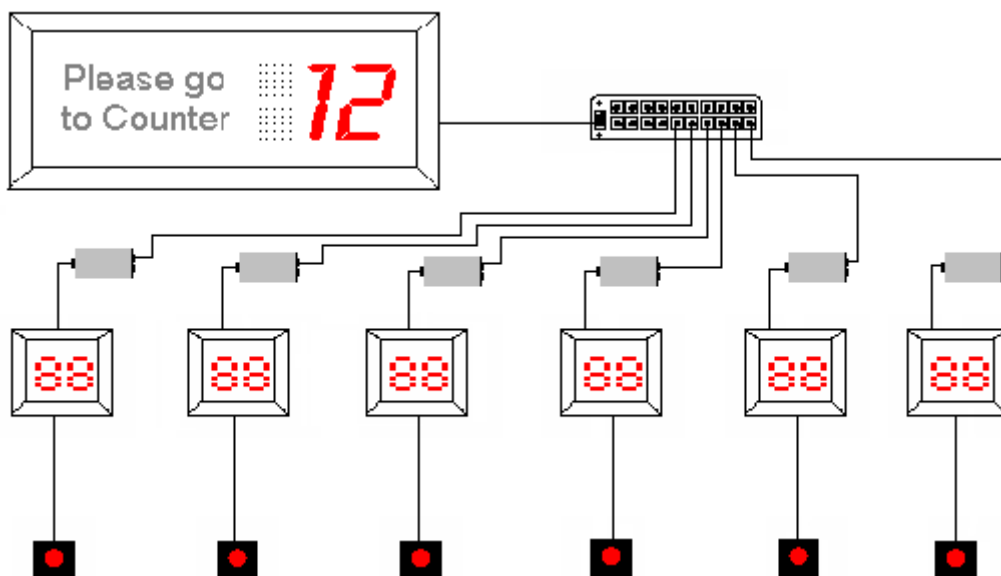



QUEUE SOLUTIONS C series

Model No.	Item
JQC 200	Control box – RS485
JQC 202	Main board- 10cm high LED digits
JQC 231	2 digit Counter display10 cm high digits
JQC 240	Call button to announce available location
JQC 260	12VDC 4.5A Power supply
JQC 270	Wiring Bus (1 per counter)
JQC 280	Voice announcement in English

Installation extra subject to site survey. VAT and Delivery extra. Lead time 4-6 weeks